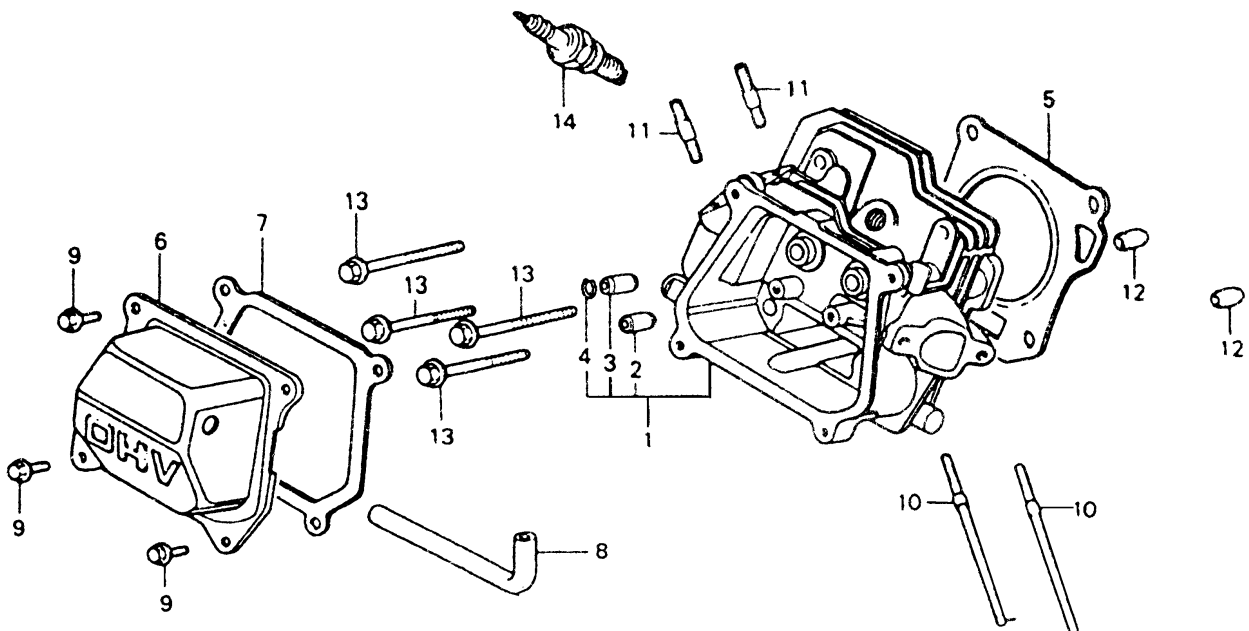

Fig.1 Cylinder head

Ref. No	Part No.	Description	Reqd. No.
1-1	168F(A).2.1.1	HEAD COMP.,CYLINDER	1
1-2	168F.2.1.1-3	GUIDE, IN. VALVE	1
1-3	168F.2.1.1-5	GUIDE, EX. VALVE	1
1-4	168F.2.1.1-4	CLIP, VALVE GUIDE	1
1-5	168F.2.3	GASKET, CYLINDER HEAD	1
1-6	168F.2.2	COVER COMP., HEAD	1
1-7	168F.2.2-2	PACKING, HEAD COVER	1
1-8	168F.2.2-3	TUBE, BREATHER	1
1-9	GB5787	BOLT, FLANGE, 6×12	4
1-10	168F.2.1-1	BOLT, STUD, 6×110	2
1-11	168F.2.1-7	BOLT, STUD, 8×32	2
1-12	125-4-6	PIN, DOWEL, 10×14	2
1-13	GB5787	BOLT, FLANGE, 8×60	4
1-14		PLUG, SPARK (F7TC)	1

□ 1



**Fig.2 Cylinder barrel**

Ref.No	Part No.	Description	Reqd. No.
2-1		GOVERNOR KIT	1
2-2	168F(A).1	BARREL ASSY., CYLINDER	1
2-3	168F.1-7	SWITCH ASSY., OIL LEVEL	1
2-4	168F.1.3	GOVERNOR ASSY	1
2-5	168F.1.3-6	WEIGHT, GOVERNOR	2
2-6	168F.1.3-5	HOLDER, GOVERNOR WEIGHT	1
2-7	168F.1.3-7	PIN, GOVERNOR WEIGHT	2
2-8	168F.1.3-4	SLIDER, GOVERNOR	1
2-9	168F.1-4	SHAFT, GOVERNOR ARM	1
2-10	168F.1-1	BOLT, DRAIN PLUG	2
2-11	168F.1.3-3	WASHER, THRUST, 6MM	1
2-12	168F.1-2	WASHER, DRAIN PLUG , 10MM	2
2-13	168F.1.3-2	CLIP, GOVERNOR HOLDER	1
2-14	GB276	BEARING, RADIAL BALL 6205/P5	1
2-15	168F.1-3	OIL SEAL, 25×41×6	1
2-16	168F.1-7	O-RING, 14MM	1
2-17	GB6177	NUT, FLANGE,10MM	1
2-18	GB848	WASHER, PLAIN, 6MM	2
2-19	168F.1-5	PIN, LOCK, 8MM	1
2-20	GB5787	BOLT, FLANGE,6×12	2

02

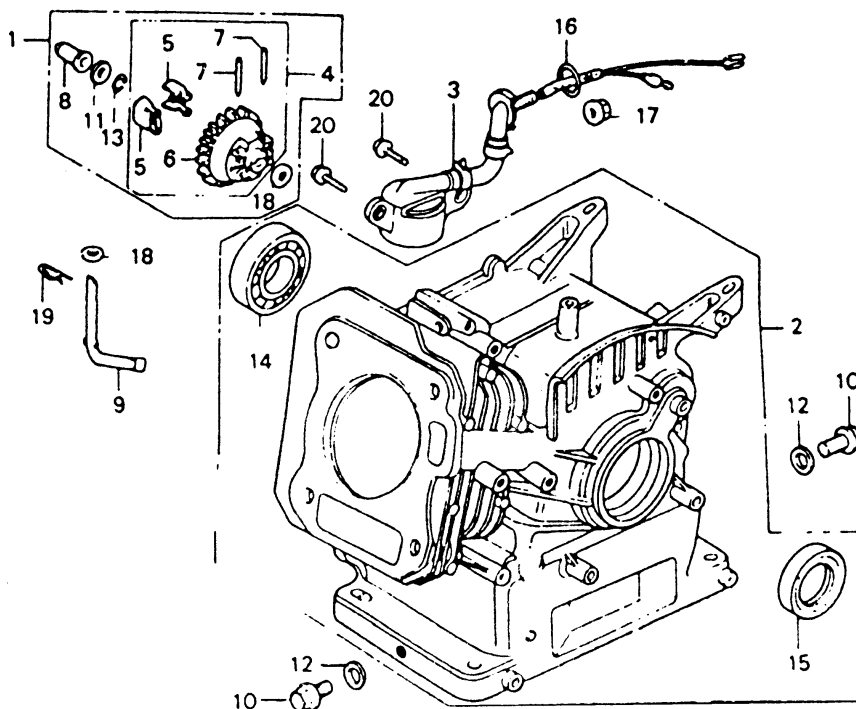

**Fig.3 Crankcase cover**

Ref. No	Part No.	Description	Reqd. No.
3-1	168FA-2.2-3 168F-2.2-5	COVER ASSY. ,CRANKCASE	1
3-2	168F.7-4	PACKING,CASE COVER	1
3-3	168F.7-2	CAP ASSY. , OIL FILLER	1
3-4	168F.7-6	CAP OIL HOLE	1
3-5	168F.7-3	PACKING,OIL FILLER CAP	1
3-6	GB5787	BOLT, FLANGE, 8×30	6
3-7	GB276	BEARING, RADIAL BALL 6205/P5	2
3-8	168F.1-3	OIL SEAL, 25×41×6	1
3-9	125-3-8	PIN, DOWEL, 8×14	4
3-10	168F-2.2-3	PACKING,CASE COVER	1
3-11	168F-2.2-1	COVER REDUCTION BOX	1
3-12	GB5787	BOLT, FLANGE, 6×25	5

□ 3

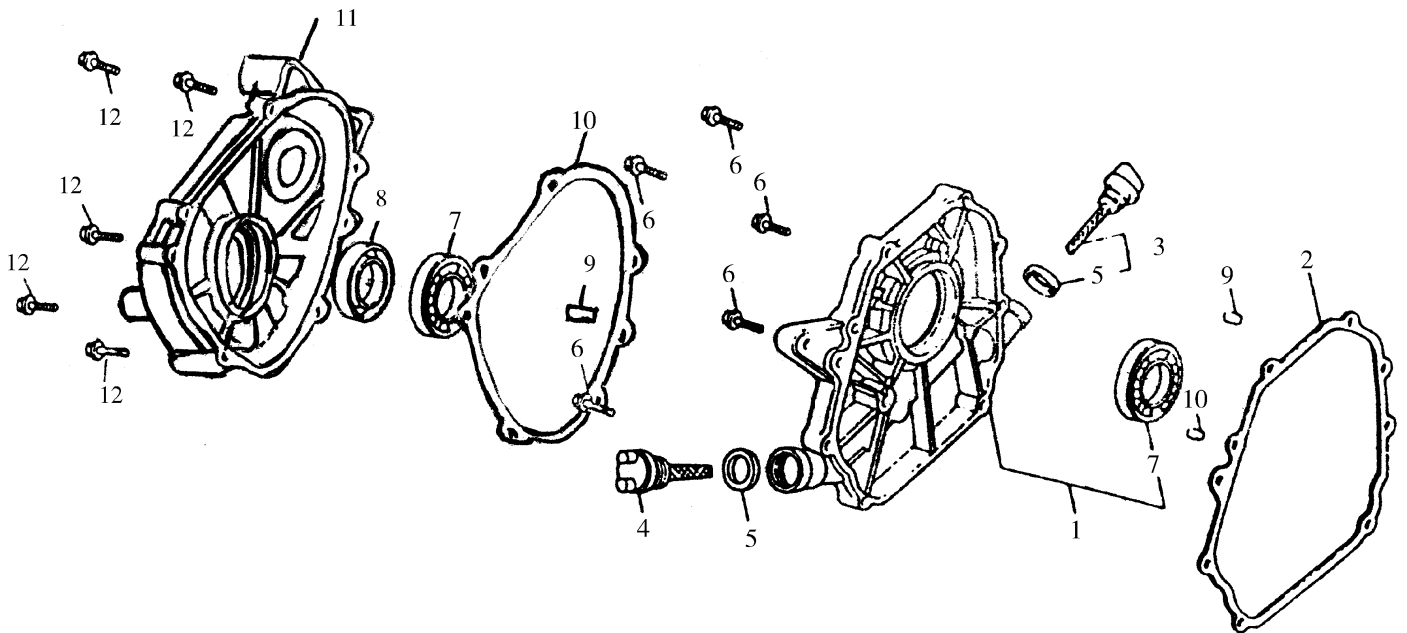

**Fig. 4 Flywheel · Ignition coil**

Ref. No	Part No.	Description	Reqd. No.
4-1	168F.4-1	FAN, COOLING	1
4-2	168F.4-2	PULLEY, STARTER	1
4-3	168F.6	COIL ASSY, IGNITION	1
4-4	168F.6	TERMINAL ASSY., HIGH TENSION	1
4-5	168F.6.1	FLYWHEEL COMP.	1
4-6	GB5787	BOLT, FLANGE, 6×25	2
4-7	168F.4-3	NUT, SPECIAL, 14MM	1
4-8	168F.4-4	KEY, WOODRUFF,	1

□ 4

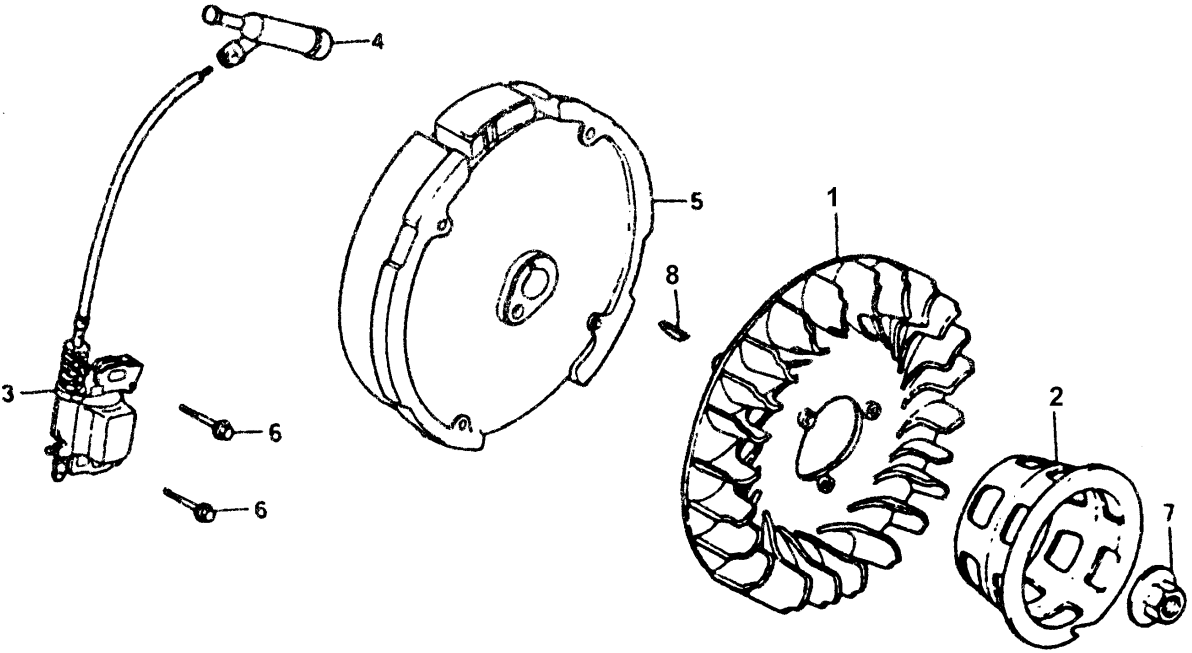

**Fig.5 Piston Connecting rod · Crankshaft**

Ref. No	Part No.	Description	Reqd. No.
5-1	168F.3-2~4	RING SET, PISTION	1
5-2	168F(A).3-1	PISTION	1
5-3	168F.3-6	PIN, PISTION	1
5-4	168F.3-7~9	ROD ASSY. , CONNECTING	1
5-5	168F(A)-2.1	CRANKSHAFT COMP.	1
5-6	168F.4-5	GEAR, TIMING	1
5-7	168F.4-7	GEAR, GOVERNOR DRIVE	1
5-8	168F.3-9	BOLT, CONNECTING ROD	1
5-9	168F.3-5	CLIP, PISTION PIN	2
5-11	168F-2.1-1	AXLE SLEEVE	1
5-12	168F-2.1-4	GEAR, CHAIN WHEEL	1
5-13	168F-2.1-3	WASHER	1
5-14	GB5787	BOLT. FLANGE, 8×20	1
5-15	168F-2.2-3	CHAIN AXLE	1
5-16	168F-2.2-4	CHAIN	1
5-17	168FA-2.2-2	CHAIN	1
5-18	168FA-2.1-2	GEAR, CHAIN WHEEL	1
5-19	168FA-2.2-1	CHAIN AXLE	1

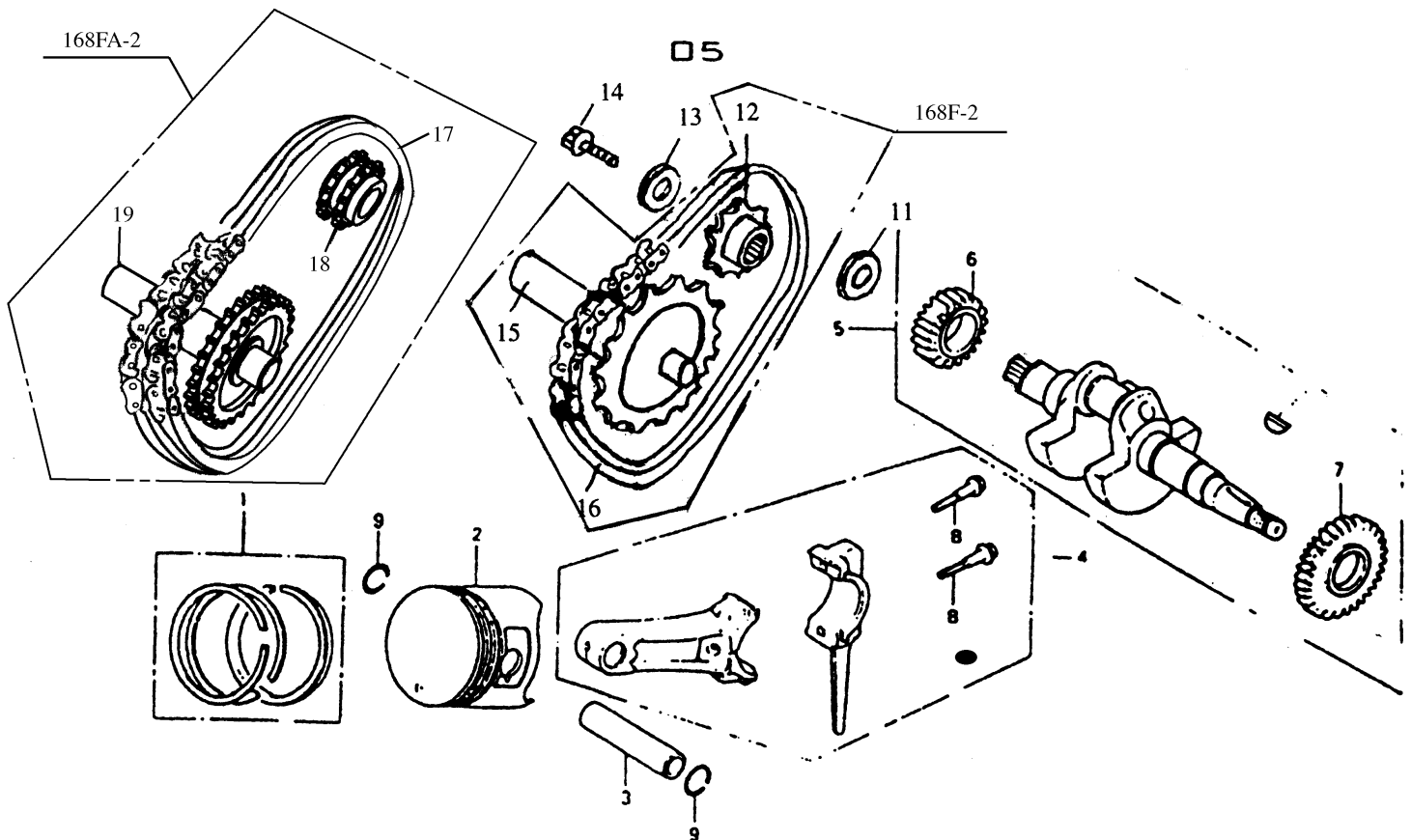

**Fig. 6 Camshaft**

Ref. No	Part No.	Description	Reqd. No.
6-1	168F(A).1.2	CAMSHAFT ASSY.	1
6-2	168F.2-6	ROD, PUSH	2
6-3	168F.2-2	ARM, VALVE ROCKER	2
6-4	168F.1-6(168FA.1-1)	LIFTER, VALVE	2
6-5	168F.2-3	PIVOT, ROCKER ARM	2
6-6	168F.1.2-6	SPRING, WEIGHT RETURN	1
6-7	168F.2.1-2	VALVE, IN.	1
6-8	168F.2.1-6	VALVE, EX.	1
6-9	168F.2.1-3	SPRING, VALVE	2
6-10	168F.2.1-4	RETAINER, IN. VALVE SPRING	1
6-11	168F.2.1-5	RETAINER, EX. VALVE SPRING	1
6-12	168F.2-9	ROTATOR, VALVE	1
6-13	168F.2-4	PLATE, PUSH ROD GUIDE	1
6-14	168F.2.1-7	BOLT, PIVOT	2
6-15	168F.2-5	NUT, PIVOT ADJUSTING	2

□ 6

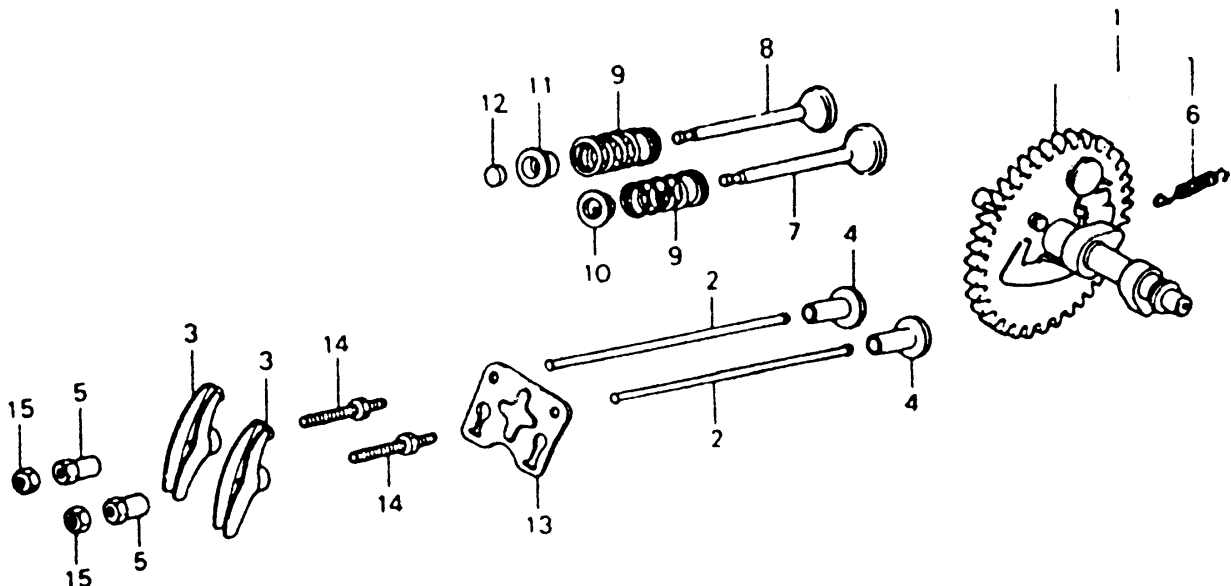

**Fig. 7 Fan cover · Side plate**

Ref. No	Part No.	Description	Reqd. No.
7-1	168F.1-7	ALERT UNIT, OIL	1
7-2	168F.5.2	COVER COMP., FAN	1
7-3	168F.5.2.2-1	PLATE, SIDE	1
7-4	168F.5.2-1	SHROUD COMP.	1
7-5	168F.5.3	SWITCH ASSY., ENGINE STOP	1
7-6	168F.6	CORD, STOP SWITCH	1
7-7	GB5786	BOLT, FLANGE, 6×12	6
7-8	GB5787	BOLT, FLANGE, 6×20	1
7-9	GB5786	BOLT, FLANGE, 6×10	1

07

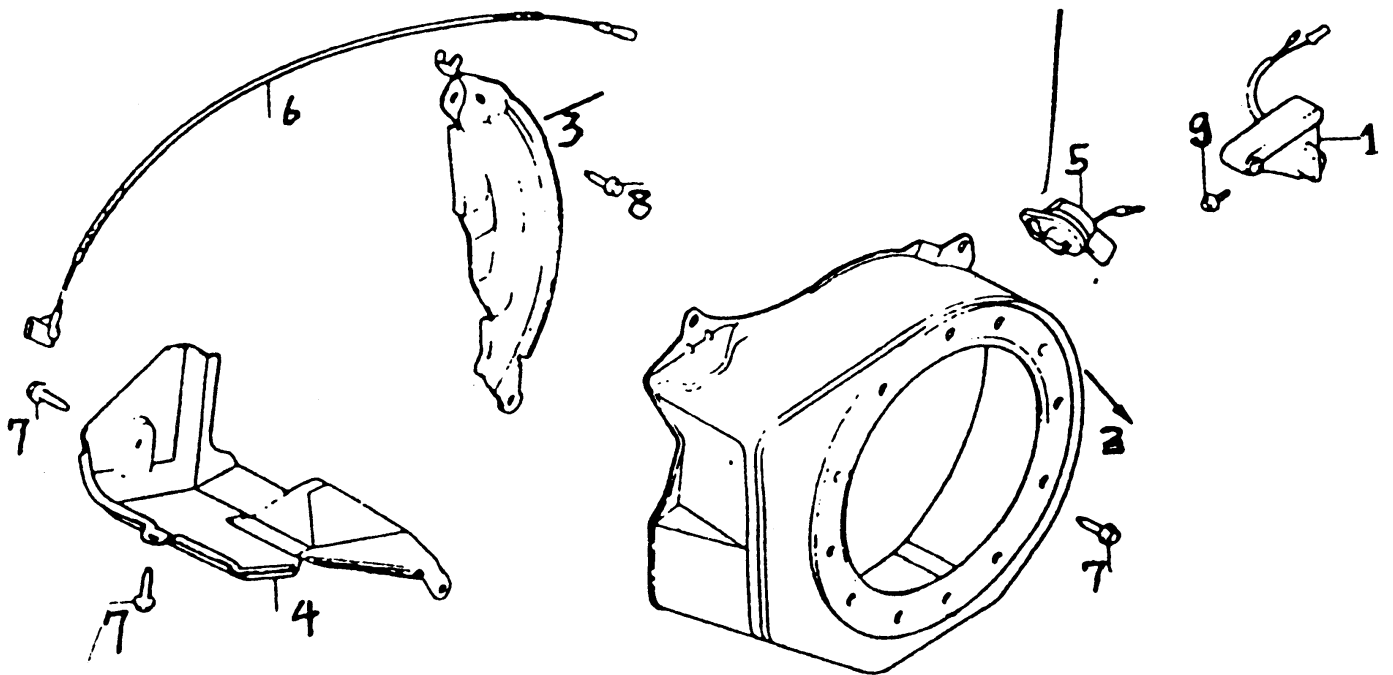

**Fig.8 Recoil starter**

Ref. No	Part No.	Description	Reqd. No.
8-1	168F.5.1	STARTER ASSY., RECOIL	1
8-2	168F.5.1.1-2	CASE COMP., RECOIL STARTER	1
8-3	168F.5.1-4	PULLEY, RECOIL STARTER	1
8-4	168F.5.1	RATCHET, STARTER	1
8-6	168F.5.1-3	PLATE, FRICTION	1
8-7	168F.5.1-5	SPRING, FRICTION	1
8-8	168F.5.1-5	SPRING, RECOIL STARTER	1
8-9	168F.5.1.1-3	GUIDE, RATCHET	1
8-10	168F.5.1.1-2	CASE, RECOIL STARTER SPRING	1
8-11	168F.5.1-6	WASHER, STARTER	1
8-12	168F.5.1-7	SHAFT, SUB	1
8-13	GB5787	BOLT, FLANGE, 6×8	1
8-14	168F.5.1-8	KNOB, RECOIL STATER	1
8-15	168F.5.1-9	ROPE, RECOIL STATER	1
8-16	168F.5.1	EMBLEM (EXTERNAL)	1
8-17	GB5787	BOLT, FLANGE, 6×10	3

□ 8

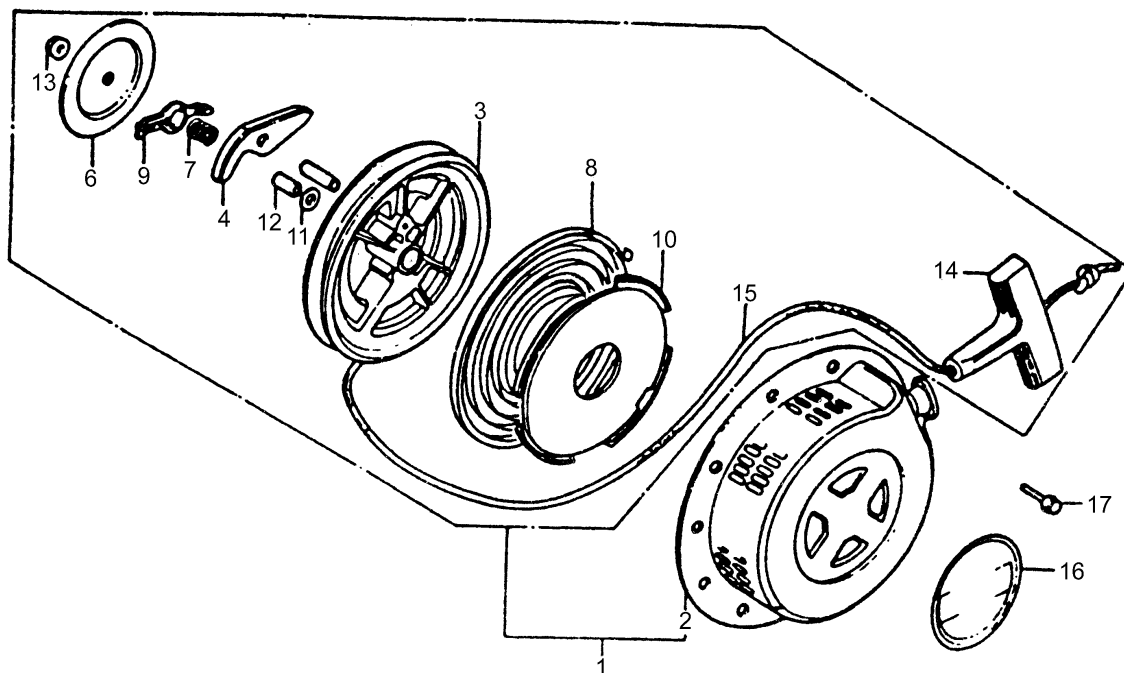

Fig. 9 Control

Ref. No	Part No.	Description	Reqd. No.
9-1	168F.8-1	ARM, GOVERNOR	1
9-2	168F.8-3	ROD, GOVERNOR	1
9-3	168F.8-4	SPRING, GOVERNOR	1
9-4	168F.8-5	SPRING, THROTTLE RETURN	1
9-5	168F8.1	CONTROL ASSY.	1
9-6	168F.8.1-1	LEVER, CONTROL	1
9-7	168F.8.1-4	SPRING, LEVER	1
9-8	168F.8.1-2	WASHER, CONTROL LEVER	1
9-9	168F.8.1-3	SPACER, CONTROL LEVER	1
9-10	168F.8.1.1	BASE COMP., CONTROL	1
9-11	168F.8.1-5	SPRING, CONTROL ADJUSTING	1
9-12	GB5787	BOLT, FLANGE, 6×12	1
9-13	168F.8.1.1-2	BOLT, GOVERNOR ARM	1
9-14	GB5787	BOLT, FLANGE, 6×20	1
9-15	GB6177	NUT SELF LOCK, 6MM	1
9-16	GB5787	BOLT, HEX., 6×20	1
9-17	168FGB5787	SCREW, PAN, 5×20	1
9-18	GB6177	NUT, FLANGE, 6MM	1

□ 9

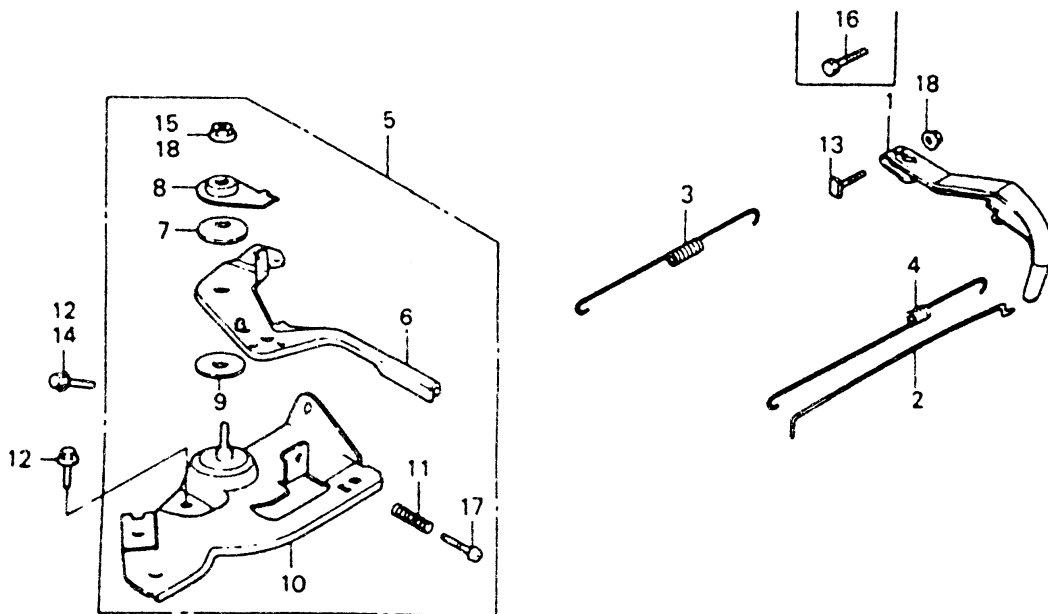

Fig. 10 Carburetor

Ref. No	Part No.	Description	Reqd. No.
10-1		GASKET SET	1
10-2		VALVE SET, FLOAT	1
10-3		FLOAT SET	1
10-4		CHAMBER SET, FLOAT	1
10-5		SCREW SET, PIOLT	1
10-6		SCREW SET, DRAIN	1
10-7		SCREW SET	1
10-8		CHOKE SET	1
10-9	168F9 (168FA5)	CARBURETOR ASSY	1
10-10		SCREW, THROTTLE STOP	1
10-11		NOZZLE, MAIN	1
10-12		PACKING, FULE STRAINER CUP	1
10-13	168F2-11	INSULATOR, CARBURETOR	1
10-14	168F2-10	PACKING, INSULATOR	1
10-15	168F2.4	SPACER COMP, CARBURETOR	1
10-16	168F2-12	PACKING, CARBURETOR	1
10-17		LEVER COMP, CHOKE	1
10-18		LEVER COCK	1
10-19		PLATE, LEVER SETTING	1
10-20		SPRING, COCK LEVER	1
10-21		PAKING, FULE COCK	1
10-22		CUP, FULE STRAINER	1
10-23		SCREW, PAN, 3x8	2
10-24		PIN, SPRING	1
10-25		JET, MAIN	1
10-26		JET SET, PILOT	1

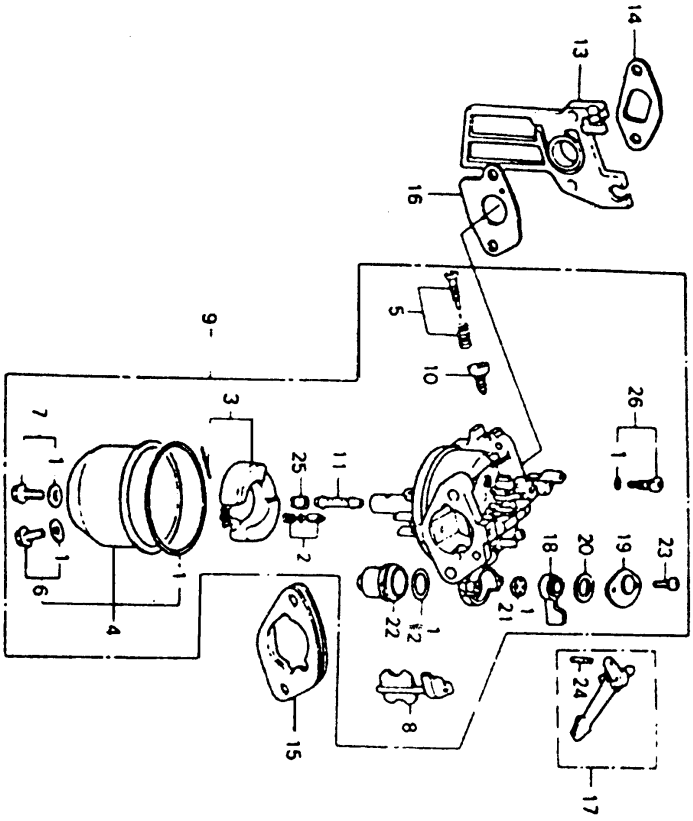

Fig.11 Air cleaner

Ref. No	Part No.	Description	Reqd. No.
11-1	168F.11-2	ELEMENT, AIR CLEANER	1
11-2	168F.11-1	GRID, AIR CLEANER	1
11-3	168F.11-3	COVER, AIR CLEANER	1
11-4	168F.11.1-1	COLLAR, AIR CLEANER	2
11-5	168F.11.1-2	COLLAR B, AIR CLEANER	1
11-6	168F.11.1	ELBOW COMP., AIR CLEANER	1
11-7	168F.11.2-1	CAP, CLEANER	1
11-8	168F.11-4	MARK, CHOKE	1
11-9	GB6177	NUT, CUP, 6MM	2
11-10	GB62-88	NUT, AIR CLEANER	1
11-11	GB5787	COVER BOLT-WASHER, 6×20	1

1 1

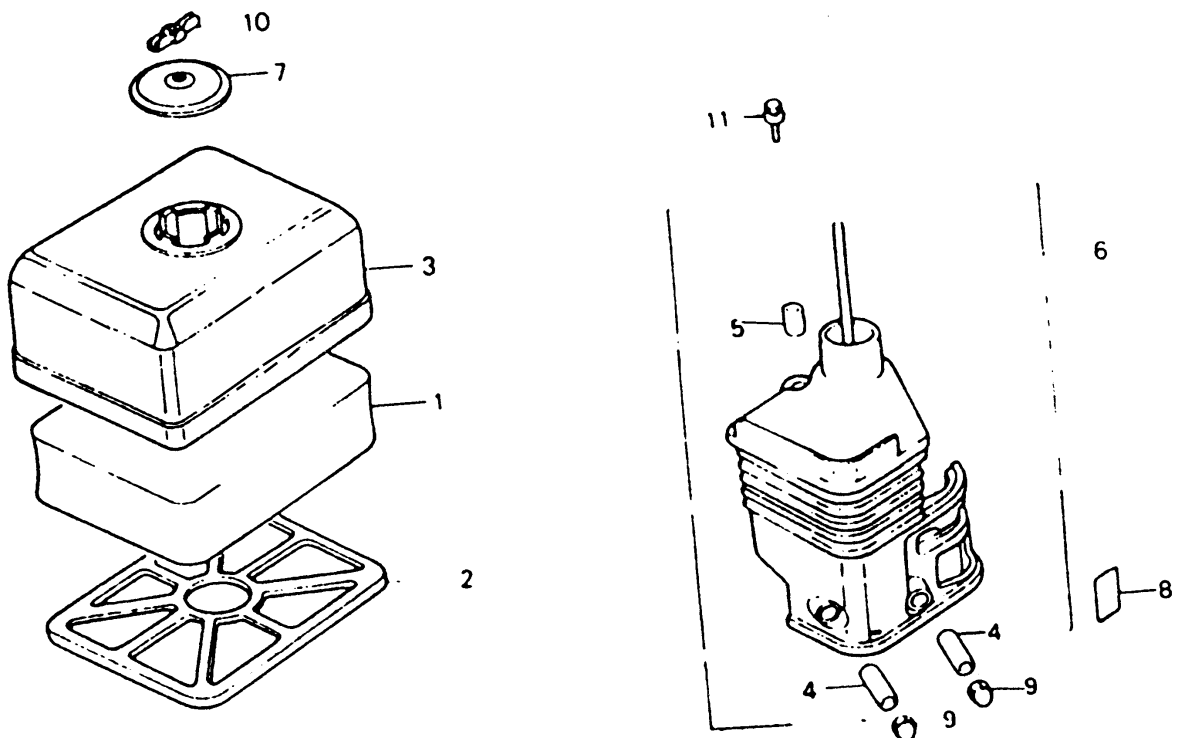

Fig.12 Muffler

Ref. No	Part No.	Description	Reqd. No.
12-1	168F. 10. 1	MUFFLER COMP.	1
12-2	168F. 10. 2-1	PROTECTOR, UPPER	1
12-3	168F. 10. 2-2	PROTECTOR, LOWER	1
12-5	168F. 2-1	GASKET, MUFFLER	1
12-6	GB818	SCREW, TAPPING, 5×8	4
12-7	GB818	SCREW, TAPPING, 4×6	3
12-8	GB6177	NUT, HEX., 8MM	2

1 2

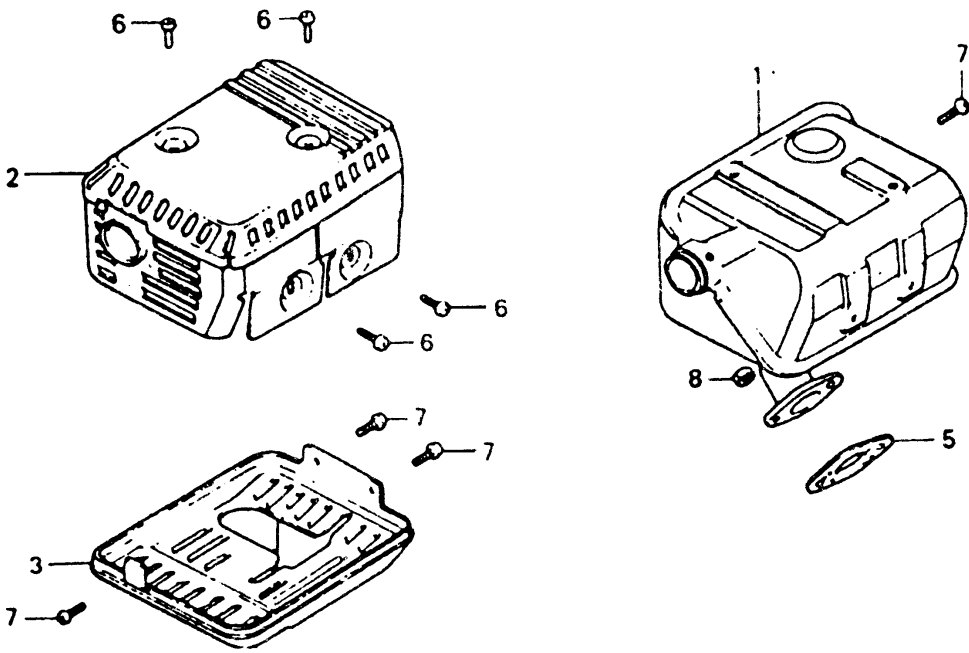
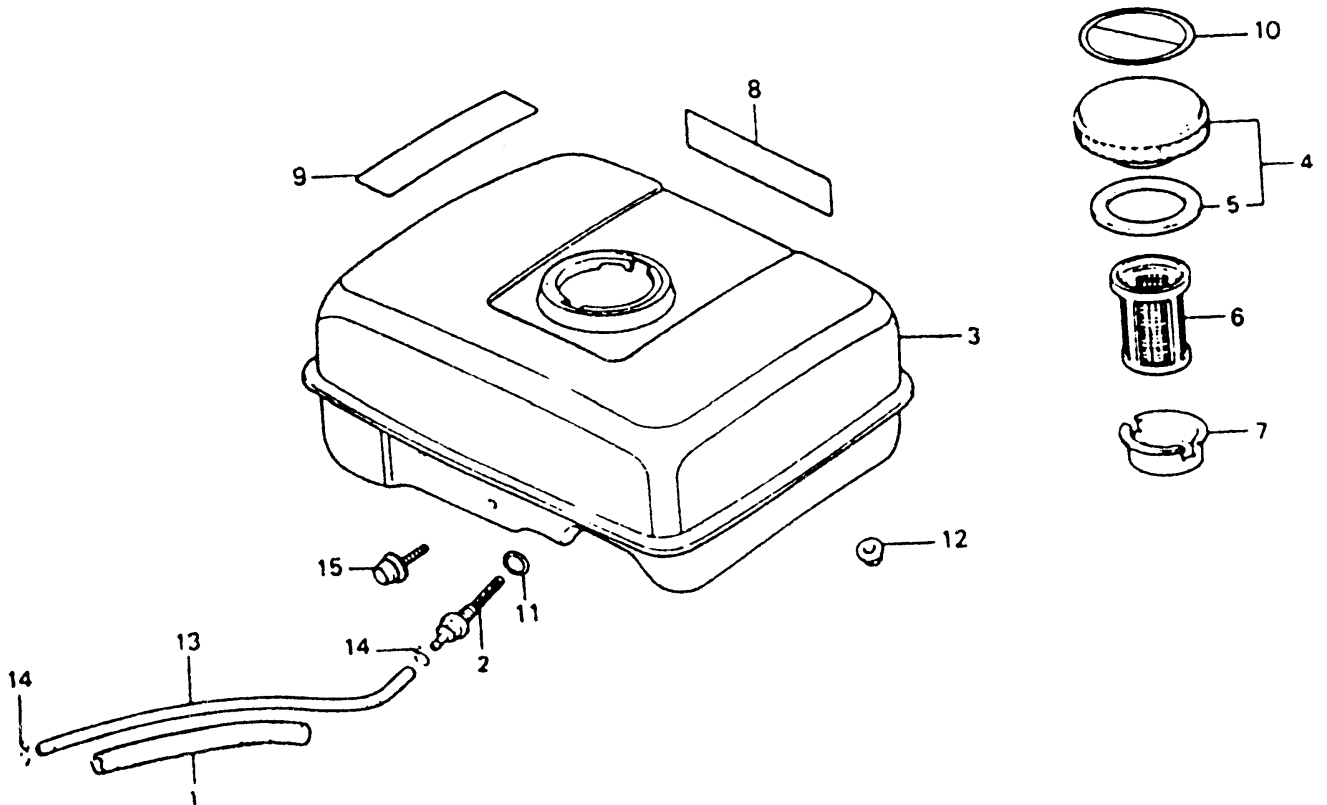

Fig. 13 Fuel tank

Ref. No	Part No.	Description	Reqd. No.
13-1	168F.12.3-1	RUBBER, SUPPORTER	1
13-2	168F.12.3.1	JOINT, FUEL TANK	1
13-3	168F.12.2	TANK COMP., FUEL	1
13-4	168F.12.1	CAPE COMP., FUEL FILLER	1
13-5	168F.12.1-3	PACKING, FUEL FILLER	1
13-6	168F.12.1-1	FILTER, FUEL	1
13-7	168F.12.1-2	HOLDER, FUEL FILTER	1 </td
13-8	168F.12-2	MARK	1
13-9	168F.12-3	MARK CAUTION	1
13-10	168F.12-5	MARK CAUTION	1
13-11	168F.12-1	O-RING 14MM	1
13-12	GB5787	NUT, FLANGE, 6MM	1
13-13	168F.12.3-2	TUBE, FUEL, 4.5×145	1
13-14	BG-328-3	CLIP B8, TUBE	1
13-15	GB5787	BOLT, FLANGE, 6×25	1

13



ZB50/ZB80水泵泵体部件明细表				
序号	图号	名称	英文	数量
1	ZB50.5-1/ZB80.5-1	接头紧固套	HOSE JINOT	2
3	ZB50.5-2/ZB80.5-2	接头密封	PACKING(PLUG)	2
2	ZB50.5-3/Z80.5-3	接头	HOSE COUPING	2
4	ZB50-7/ZB80-7	进水法兰	VALVECASE	1
5	ZB50.4/ZB80.4	进水口单向阀	CHECK VALVE	1
6	GB5783	螺栓M8×20/M10×25	BLOT M8×20/M10×25	3
7	GB5783	螺栓M8×25/M10×30	BLOT M8×25/M10×30	3
8	GB3452.1	O型圈25×2.65	O-SEALING RING	1
9	ZB80-10	水堵	PLUG	1
10	ZB50-1/ZB80-1	泵体	PUMP CASE	1
11	ZB50-8/ZB80-8	出水口密封垫	PACKING	1
12	ZB50-9/ZB80-9	出水法兰	BEND	1
13	GB5783	螺栓M8×25/M10×30	BLOT M8×25/M10×30	1
14	GB3452.1	O型圈55×5.3/75×5.3	O-SEALING RING	1
15	ZB50-5/ZB80-5	蜗壳	VOLUTE SHELL	1
16	ZB50-4/ZB80-4	叶轮	IMPELLER	1
17	ZB80.3	机械水封组件	MECHANICAL SEAL	1
18	ZB80-2	铜垫圈	WASHER	4
19	GB70.1	螺栓M8×60	BOLT M8×60	4
20	GB3452.1	O型圈194×5.3/218×5.3	O-SEALING RING	1
21	ZB50-3/ZB80-3	泵座	CASING COVER	1
22	ZB50.1/ZB80.1	机架焊合	PART NAME	1
23	GB5781	M6×16	BOLT M6×16	4
24	ZB50.2/ZB80.2	减震座组合	RUBBER BOTTOM	4
25	GB6710	NUT M6	螺母 M6	4
26	GB5783	BOLT M10×25	螺栓 M10×25	4
27	GB3452.1	O型圈25×2.65	O-SEALING RING	1
28	ZB80-10	水堵	PLUG	1
29	ZB50.6/ZB80.6	卡环	BAND HOSE	2
30	ZB50.7/ZB80.7	滤网	STRAINER COMP	1

