

噴霧機零件組合圖 PARTS DIAGRAM OF SANCHIN PUMP

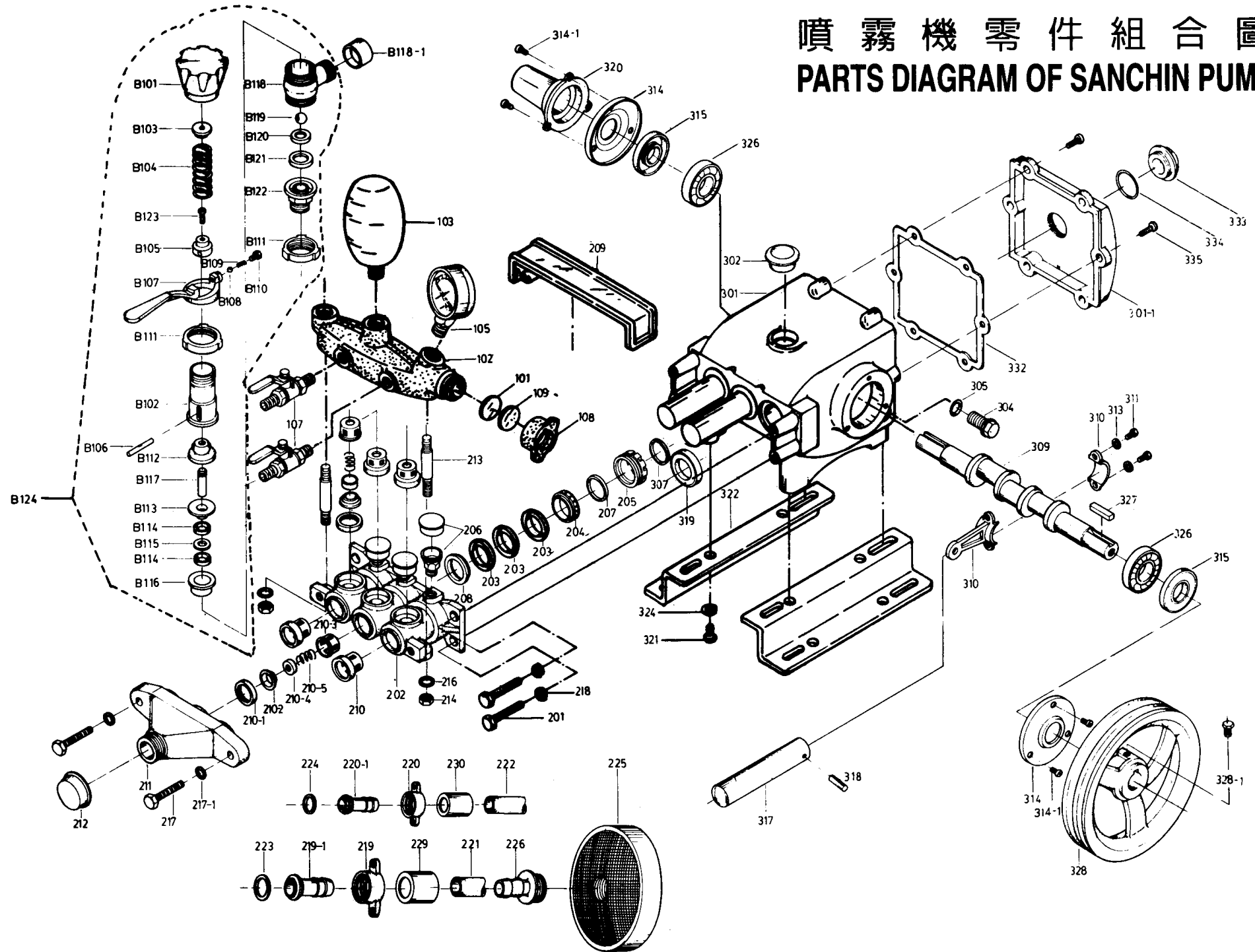

<<噴霧機零件表PARTS DIAGRAM OF SANCHIN PUMP>>

*注：訂貨時請於零件號碼前標明型式

*REMARK: Please refer to the Model of pump when order parts

零件號碼 Parts No.	零件名稱 Parts Name	數量 合計	零件號碼 Parts No.	零件名稱 Parts Name	數量 合計	零件號碼 Parts No.	零件名稱 Parts Name	數量 合計
101	出水口墊 Packing irrigation	1	201	汽缸固定螺絲 Cylinder stud bolt	4	301	曲軸箱 Crank case	1
102	出水室 Case delivery	1	202	汽缸 Cylinder V-packing	1	301-1	曲軸箱後蓋 Back cover	1
103	空氣室 Air-chamber	1	203	三角套皮 V-packing	6/9	302	注油蓋 Oil filler	1
105	壓力表 Pressuer gauge	1	204	牛油圈 Ring grease	3	304	放油塞頭 Bolt drain plug	1/2
107	出水開關 Cock	2	205	調節圈 Packing grand	3	305	放油塞頭墊皮 O-ring	1/2
108	出水口塞頭 Cap irrigation	1	206	牛油杯 Grease cap	3	307	活塞中間套皮 Seal plunger	3
109	塞頭片子 Alate irrigation	1	207	牛油套皮 Grease packing	3	309	曲柄軸 Crank shaft	1
B101	調壓柄調整螺 Pressure adjustment knob	1	208	三角套皮座 V-packing adapter	3	310	連桿 Rod(complete set)	3
B102	調壓柄彈簧筒 Spring-tube	1	209	連結擋片 grand Cover plate	1	311	連桿螺絲 Bolt rod	6
B103	調壓柄彈簧押 Spring-disc	1	210	活動弁 Valve assy	6	312	連桿螺母 But rod	6
B104	調壓柄彈簧 Regulating spring	1	210-1	活動弁皮 Valve packing	6	313	連桿華司 Washer rod	6
B105	調壓柄彈簧受 Spring seat	1	210-2	活動弁片 Valve seat	6	314	軸承匣 Bearing case	2
B106	調壓柄彈簧受棒 Pin	1	210-3	活動弁網 Spring retainer	6	314-1	軸承匣螺絲 Screw	6/8
B107	調壓柄手柄 Regulating handle	1	210-4	活動弁止片 Spring damper	6	315	軸承護油圈 Bearing oil seal	2
B108	調壓柄手柄球 Ball	1	210-5	活動弁彈簧 Valve spring	6	317	活塞 Plunger	3
B109	調壓柄手柄彈簧 Spring	1	211	吸水室 Suction part	1	318	活塞梢 Plunger pin	3
B110	調壓柄手柄螺絲 Spring nut	1	212	吸水口套 Cap-suction parts	1	319	活塞護油圈 Guode oil seal	3
B111	調壓柄本體螺帽 Valve union	2	213	出水室螺絲 Bolt stud	2	320	曲軸蓋 Shaft cap	1
B112	調壓柄蕊內墊皮 Rubber pad	1	214	出水室螺帽 Nut stud	2	321	曲軸箱座螺絲 Base plate screw	4
B113	調壓柄止水皮押 Bowl cap	1	216	出水室華司 Washer stud	2	322	曲軸箱座 Base plate	2
B114	調壓柄壓珠棒套皮 Spindle-packing	2	217	吸水室螺絲 Bolt-suction	2	324	曲軸箱座華司 Spring washer	4
B115	調壓柄珠棒華司 Ball-washer	1	217-1	吸水室華司 Washer-suction	2	326	軸承 Bearing	2
B116	調壓柄壓珠棒套皮座 Packing seat	1	218	汽缸固定彈簧華司 Washer cylinder	4	327	皮帶輪梢 Key pulley	1
B117	調壓柄壓珠棒 Spindle	1	219	吸水管接頭 Coupling suction	1	328	皮帶輪 V-pulley	1
B118	調壓柄本體 Valve body	1	219-1	吸水管申木 Joint suction	1	328-1	皮帶輪螺絲 Bolt pulley	1
B118-1	調壓柄口套 Overflow cap	1	220	回水管接頭 Coupling overflow	1	332	曲軸箱後蓋墊皮 Packing back cover	1
B119	調壓柄球 Check-ball	1	220-1	回水管申木 Joint overflow	1	333	油鏡 Oil gauge	1
B120	調壓柄球座 Valve ball seat	1	221	吸水管 Suction hose	1	334	油鏡墊皮 Packing oil gauge	1
B121	調壓柄球座墊皮 Leather packing	1	222	回水管 Overflow hose	1	335	曲軸箱後蓋螺絲 Screw	6/8
B122	調壓柄固定座接頭 Joint	1	223	吸水管申木墊皮 Packing suction	1			
B123	調壓柄彈簧受螺絲 Tighten screw	1	224	回水管申木墊皮 Packing overflow	1			
B124	調壓柄全組 Regulator complete unit	---	225	過濾頭 Strainer	1			
			226	過濾頭接頭 Strainer joint	1			
			229	吸水管銅套 Socket suction	1			
			230	回水管銅套 Socket overflow	1			